

DETAIL OF SEPTIC TANK

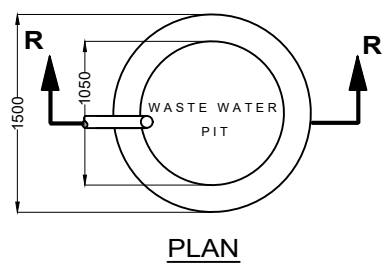

DETAIL OF WASTE WATER PIT

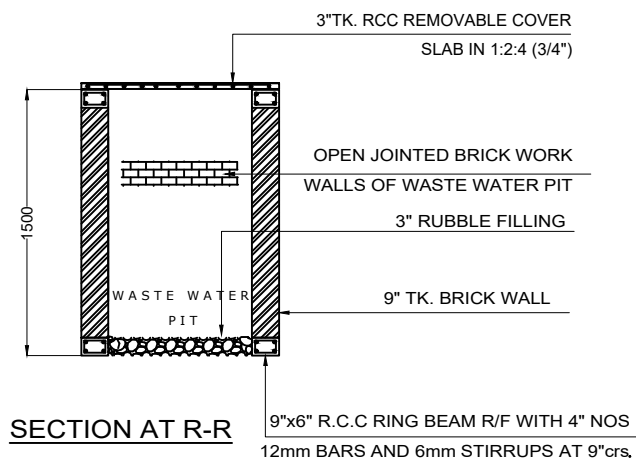
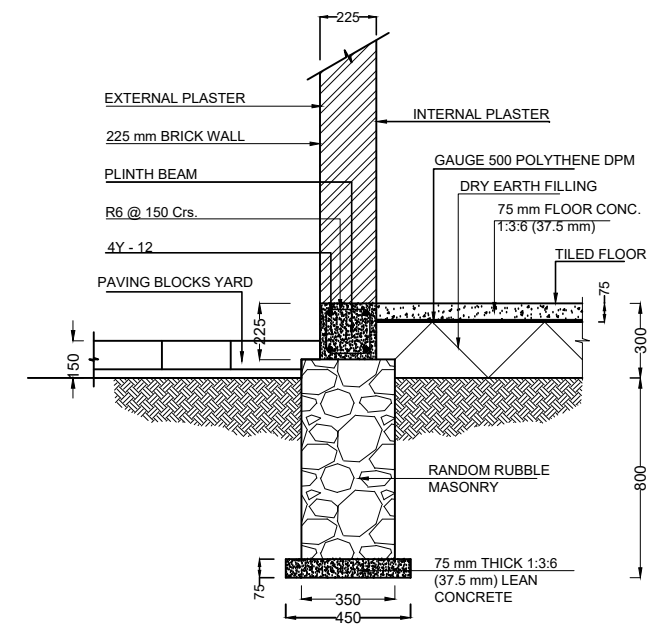

DETAILS OF WALL FOUNDATION

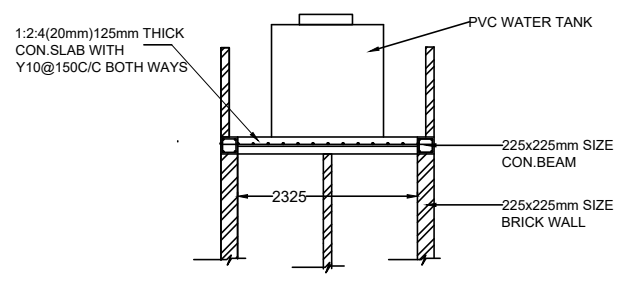

WATER TANK SLAB DETAIL
(Water tank slab height 3000mm above Wash room)

PROJECT :		MODIFICATION OF L.F.S.MATHUGAMA -MPCS	
TITLE:			
Designed	R.S		
Drawn	C.P	PRABATH	
Checked	R.S		
Approved	G.P.K.Wijekoon Manager (E&P)		
Scale	AS.SHOWN	Date:	16.03.2026
Rev.No	Drawing No:		CEYPET/ENG/ 0612
CEYLON PETROLEUM CORPORATION ENGINEERING DEPARTMENT NO. 609, DR. DANISTER DE SILVA MAWATHA, DEMATAGODA, COLOMBO -09, TP. NO. 5661717, 5661818 FAX 5455408		Sheet: 03 of 03	